

SV43-Thru Hull



This light has an LED array in a bronze housing designed for smaller boats that want LED lighting. This light is excellent for any boat which has limited interior access but desires a thru hull installation avoiding any exterior wiring.



Patent Pending

SV43 technical specifications

Application for:	GRP / fiberglass / wood hulls
Lamp:	LED array, available in white or blue
Life length:	approx. 10,000 hours
Kelvin color temp:	6500
Glass lens:	Convex crown glass
Thickness:	0.51" / 13mm
Diameter:	1.12" x 28.5mm
Power supply:	12 volt d.c. - 0.35 amps
Casing material:	Marine Bronze
Dimensions:	Diameter: 2.36" / 60mm Length: 6.61" / 168mm

Weight:	0.661 kgs / 1.5 lbs
Code:	SV43 – Thru hull
Total shipping weight:	0.91 kgs / 2.0 lbs
Installation:	recommended at minimum 6" (150mm) below waterline between 3-6 feet (1-2 meters) apart. The placement of surface mounted underwater lights on the hull bottom or sides is not recommended

All information is subject to change without prior notice, please confirm details prior to ordering.



1881 W State Road 84, Bay 102, Fort Lauderdale, FL 33315 USA
T. 954 760 4447 Toll Free 1 866 772 0130 F. 954 525 3261
sales@seavision.com www.seavision.com

SV43 Light



Introduction:

Congratulations on the purchase of your new thru hull LED light (Patent Pending). Underwater Lights® USA, LLC takes pride in providing well designed, high quality and thoroughly tested lights that allow you to “enhance your boating experience”. These lights can be installed in your vessel for aesthetics, to attract fish, for security and safety.

Important Information, Please Save

General Operating Information:

The commercial grade Light Emitting Diode (LED) technology used in this light will provide robust and reliable operation under normal operating conditions.

The light cannot be operated when the vessel is out of the water, however, the light can be operated while the vessel is underway.

Depending upon water clarity conditions, the light beam can reach up to 6 meters (20 feet).

General Safety Information:

This light is intended for use on fiberglass and wood hulled vessels.

Never try to install or remove this light while the vessel is in the water.

The body of the light must be electrically joined to the vessels grounding and cathodic protection system. Failure to do so may cause corrosion.

Always disconnect and lock-out power before working on light.

The light should be visually inspected every six months.

The light electrical cabling should be visually inspected for proper operating condition every six months

Marine growth should be removed from the glass using a soft brush to allow illumination to exit the light.

Technical Specifications:

Light source = White LED array - 200 Lumens - 6500 Kelvin color temperature - 2.5 Watts or Blue LED array - 60 Lumens - 2.5 Watts - Approximately 10,000 hours life for each

Glass = Convex crown glass - 13mm (0.51”) thick - 28.5mm (1.12”) diameter net aperture

Light dimensions = 60mm (2.36”) diameter x 168mm (6.61”) long - 661 grams (1.5 lbs)

Construction = Marine bronze

Power source = 12VDC - 0.35 Amps maximum - Operating temperature from -30°C (-22°F) to 85°C (185°F)

Troubleshooting:

Please contact our technical support staff in Florida at 1-954-760-4447, Monday to Friday from 8:00 am to 5:00 pm EST.

Warranty:

Underwater Lights® USA, LLC warrants this light to be free from defects in workmanship and materials for a period of two years from the date of original purchase. Further, misuse, abuse, improper installation, neglect, improper shipping, damage caused by disasters such as fire, flood and lightning, unauthorized repair or modifications will void said warranty. Should your light prove defective during the warranty period, promptly contact Underwater Lights® USA, LLC for an RMA number and then return the light freight prepaid with the RMA number clearly marked on the outside of the shipping container.

SV43 Light

THRU HULL, LED ARRAY, 12VDC



Installation:

This light should be installed at least 125-150mm (5-6") below the water line by qualified/approved personnel using proper tools and materials. The minimum hull thickness is 10mm (0.4") and maximum is 102mm (4"). After selecting a flat surface, cut a 19mm (0.75") diameter hole through the vessel hull in the desired location. Caution! Check that no electrical wiring, fuel lines, oil lines, water lines etc., pass near or through the intended hole location.

Remove Locking Ring (10) and Compression Ring (9) from Main Body (2). Carefully coat Main Body (2) and inner surface of hull hole with 3M 5200 Marine Adhesive or equivalent. Caution! Avoid placing excess adhesive on Main Body (2) threads. Note: Exposed inner hole surface must be properly sealed before light installation to prevent potential water intrusion into the hull proper. Holding Front Flange (1), push Main Body (2) through hull hole, slide Compression Ring (9) over Main Body (2), and then install Locking Ring (10) hand tight. Note: Ensure that the tips of all three Set Screws (11) are NOT touching Compression Ring (9). After the 3M 5200 Marine Adhesive is fully cured, evenly tighten three Set Screws (11) to 7 Nm (5 ft/lbs) using a 3mm allen wrench. Also, it is highly recommended that Front Flange (1) be coated with antifouling paint and a wire lead be connected from Locking Ring (10) tapped hole (M4 x 0.7 thread) to the vessels grounding and cathodic protection system.

Connect RED wire lead to a switched and fused power source and connect BLACK wire lead to a good ground.

Serviceable Parts:

The LED Array (7) and Electrical Cable (12) are not field serviceable on this light, but Strain Relief O-ring (13) and Cable Strain Relief (14) are field serviceable. Also, Convex Glass (4), Glass O-ring (5) and Main Body O-ring (6) can be replaced by removing five Socket Flat Head Screws (8) and carefully separating Front Flange (1) from Main Body (2). Note: Evenly hand tighten the five Socket Flat Head Screws (8) after carefully re-assembling said parts.

MODELS G11A11B25, 12VDC/WHITE & G11A11B26, 12VDC/BLUE		
BALLOON	PART	DESCRIPTION
1	43019	FRONT FLANGE, BRONZE*
2	43024	MAIN BODY, BRONZE*
3	43011	GLASS BACKUP RING
4	43012	CONVEX GLASS
5	43013	GLASS O-RING
6	43014	MAIN BODY O-RING
7	43015 43044	WHITE LED ARRAY BLUE LED ARRAY
8	43040	M3 x 0.5 x 8 LG SST SOCKET FLAT HEAD SCREW
9	43029	COMPRESSION RING, BRONZE*
10	43034	LOCKING RING, BRONZE*
11	43039	M6 x 1.0 x 16LG SST SOCKET SET SCREW
12	43018	ELECTRICAL CABLE
13	43041	STRAIN RELIEF O-RING
14	43042	CABLE STRAIN RELIEF

*PLEASE CALL FOR OTHER LIGHT COMPONENT CONFIGURATIONS

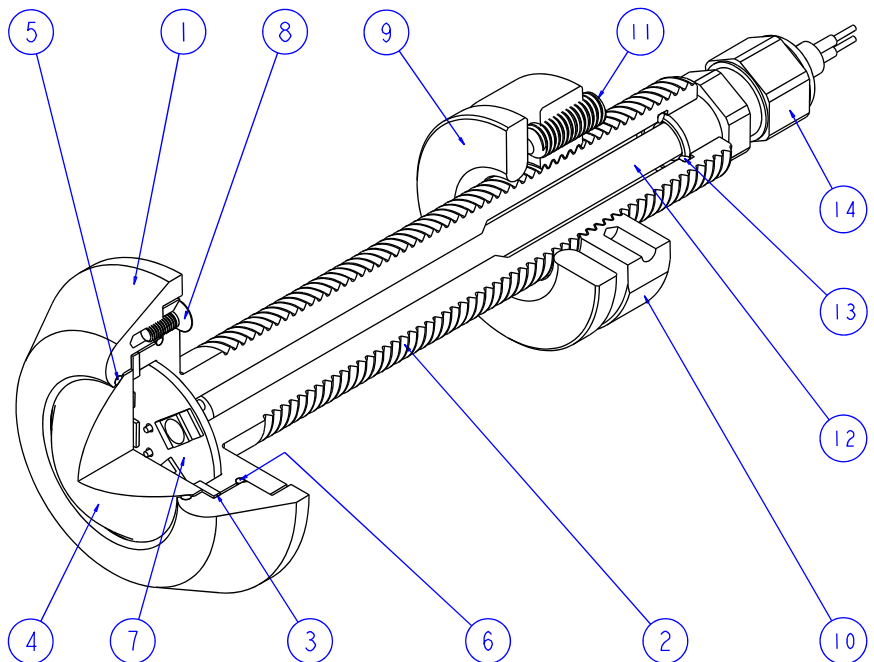

Underwater Lights USA, LLC
 1881 W State Road 84, Bay 102
 Fort Lauderdale, FL 33315 USA
 Phone: 1-954-760-4447
 Fax: 1-954-525-3261
 Internet: www.seavision.com
 Email: sales@seavision.com

DOC:060707-4

Underwater Lights Europe Sarl
 16 rue Rouaze
 06400 Cannes, France
 Phone: 33-(0)-4-97-21-02-96
 Fax: 33-(0)-4-97-21-10-96
 Internet: www.seavision.com
 Email: sales@seavisioneurope.com